

Time: 2 hours

Max. Marks 60

N.B.

1. Question No.1 is compulsory
2. Attempt any Three Questions from the remaining Five Questions
3. Figures to the right indicate full marks
4. Atomic weight: C = 12, H = 1, O = 16, N = 14, S = 32, Cl = 35.5

10/12/24

Q.1 Answer any five from the following:

15

- a. Write a note on Galvanic corrosion.
- b. Define knocking. Give its disadvantages.
- c. Give the difference between fluorescence and phosphorescence.
- d. Explain in brief electrolytic cell with example.
- e. What is Green chemistry? Give its significance.
- f. Explain absorption spectrum in brief with diagram.
- g. 1.4 g coal sample was kjeldahlised. Blank titration required 25 ml of 0.1 N NaOH solution. After absorption of liberated ammonia in 0.1N of sulphuric acid solution, back titration required 5 ml of 0.1N NaOH solution. Calculate percentage of nitrogen.

Q.2 a) Explain by which mechanism does rusting of iron takes place in acidic medium with the help of reactions and diagram.

6

b) Explain trans-esterification method for preparation of biodiesel from vegetable oil with reaction and give its advantages.

5

c) Write the cell reactions and calculate the standard emf of the following cell:

4



$$\text{Given: } E_{\text{Zn}}^{\circ} = -0.763 \text{ V and } E_{\text{Cu}}^{\circ} = 0.337 \text{ V.}$$

Q.3 a) What is Flame photometry? Explain it with respect to principle, working, diagram and applications.

6

b) Give construction and working of any one reference electrode with the help of diagram and reactions.

5

c) Calculate %atom economy for the following reaction with respect to cinnamaldehyde:

4

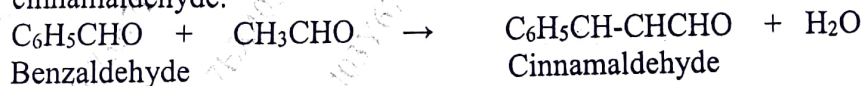

- Q.4 a) Calculate the volume and weight of air required for complete combustion of 1 m³ of gaseous fuel having the following composition: H₂ = 35%, C₂H₆ = 25%, CH₄ = 35%, N₂ = 2%, CO₂ = 1%, O₂ = 2.0% (Molecular weight of air = 28.949). 6
- b) Explain the conventional and greener pathway for the synthesis of Indigo. Mention the principle associated with this synthesis. 5
- c) Explain any two selection rules in spectroscopy. 4
- Q.5 a) Explain the mechanism of 'Rusting of iron in water' with the help of diagram and reactions. 6
- b) Determine %C & %H from the following observations in experiments of analysis of coal: 2.5g coal on burning in a combustion tube and passing the gases through tubes containing anhydrous CaCl₂ and KOH, increases their weight by 1.2g and 8.5g respectively. 5
- c) Draw a well labelled Jablonski diagram. 4
- Q.6 a) Explain sacrificial anode cathodic protection method of metal from corrosion with its principle, suitable diagram and applications. 6
- b) A sample of coal was found to contain C = 77%, H = 5%, S = 3%, O = 1%, N = 2%, Ash = 12%. Calculate HCV and LCV using Dulong's Formula. 5
- c) Draw a well labelled diagram of electromagnetic spectrum showing various regions. 4

FE (SEM II) / R-19 C shome / AI Branch

QP code - 1006927

03/12/24

(Time: 3 hours)

Max Marks: 80

- Note: (1) Question No. 1 is Compulsory.
 (2) Answer any three questions from Q.2 to Q.6.
 (3) Figures to the right indicate full marks.

Q1.

- a) Solve: $(1 + e^{\frac{x}{y}}) dx + e^{\frac{x}{y}} (1 - \frac{x}{y}) dy = 0$ 5
- b) Solve: $(D^2 - 4D + 4)y = e^x + \cos 2x$ 5
- c) Compute the value of $\int_0^{\frac{\pi}{2}} \sqrt{\sin x + \cos x} dx$ using Simpson's $3/8^{\text{th}}$ rule by dividing into six sub intervals 5
- d) Change the order of Integration: $I = \int_0^4 \int_{y/2}^{9-y} f(x, y) dx dy$ 5

Q2.

- a) Solve: $\frac{d^2y}{dx^2} - y = x^2 \sin 3x$ 6
- b) Solve: $(y \log y) dx + (x - \log y) dy = 0$ 6
- c) Apply Runge- Kutta method of fourth order to find an approximate value of y when $x = 0.4$ by taking $h = 0.2$ for $\frac{dy}{dx} = \frac{y-x}{y+x}$; $y(0) = 1$ 8

Q3.

- a) Using DUIS Rule, show that $\int_0^1 \frac{x^a - 1}{\log x} dx = \log(1 + a)$; $a \geq 0$ 6
- b) Evaluate $\iint y dx dy$ over a region bounded by $y = x^2$ and $x + y = 2$ 6
- c) Evaluate: $\int_0^2 \int_0^x \int_0^{2x+2y} e^{x+y+z} dz dy dx$ 8

Q4.

- a) Find using double integration the area of the cardioid $r = a(1 - \cos \theta)$ lying outside the circle $r = a \cos \theta$ 6
- b) Using Euler's method find $y(0.5)$ for $\frac{dy}{dx} = 1 + xy$; $y(0) = 1$ with $h = 0.1$ 6
- c) Prove that $\int_0^{\infty} x^2 e^{-x^4} dx * \int_0^{\infty} \frac{e^{-x^2}}{\sqrt{x}} dx = \frac{\pi}{4\sqrt{2}}$



Q5.

- a) Evaluate $\iiint xyz \, dx dy dz$ over a region D by changing into cylindrical polar coordinates where region is bounded by coordinate planes, plane $z = 1$ and a cylinder $x^2 + y^2 = 1$ 6
- b) Solve $(y^4 + 2y)dx + (xy^3 + 2y^4 - 4x)dy = 0$ 6
- c) Solve by method of Variation of parameter: $(D^2 + 1)y = \sec x \tan x$ 8

Q6.

- a) Using modified Euler's method find $y(0.2)$ for $\frac{dy}{dx} = x - y^2$; $y(0) = 1$ with $h = 0.2$ 6
- b) Prove that length of the arc of the curve $y = \log\left(\frac{e^x - 1}{e^x + 1}\right)$ from $x = 1$ to $x = 2$ is $\log\left(e + \frac{1}{e}\right)$ 6
- c) Evaluate by changing to polar coordinates: 8

$$\int_0^{a/\sqrt{2}} \int_y^{\sqrt{a^2 - y^2}} \log(x^2 + y^2) \, dx \, dy \quad ; \quad a > 0$$

FE | Sem II | C-Shame R-19 | All Branch

QP-10065903

Time: 2 Hrs

Marks: 60

05/12/24

N.B:

- 1) Question No. 1 is compulsory
- 2) Attempt any three questions from Q. 2 to Q. 6
- 3) Use suitable data wherever required.
- 4) The figures to the right indicate full marks

Q. 1 Attempt any five of the following. (15)

- (a) How do you increase the resolving power of a diffraction grating?
- (b) Differentiate between single-mode and multimode fibre.
- (c) Calculate the curl of the vector function $\vec{A}(x, y, z) = y \cos x \hat{x} + (y + e^x) \hat{z}$
- (d) Draw the schematic diagram to explain the construction of photo diode optical sensor.
- (e) How fast must an electron move in order to have its mass equal to the rest mass of the proton ($1.67 \times 10^{-27} \text{ kg}$)?
- (f) Obtain the expression for Gauss's law of electrostatics in point form.
- (g) What are nanomaterials and what are their different types?

Q. 2

- (a) Discuss the phenomenon of Fraunhofer diffraction at a single slit and obtain the conditions for maxima and minima.
A plane grating just resolves two lines in the second order. Calculate the grating element if $d\lambda = 6\text{\AA}$, $\lambda = 6 \times 10^{-5} \text{ cm}$, and the width of the ruled surface is 2 cm.
(4+4)
- (b) With a neat energy level diagram explain the construction and working of a Nd-YAG Laser. State its application.
In a multimode step index fibre with $\mu_1 = 1.53$, $\mu_2 = 1.50$ and $\lambda = 1 \mu\text{m}$. If the core radius is 50 μm , calculate the normalized frequency of the fibre and the number of guided modes. (4+3)

Q. 3

- (a) Derive the expression of numerical aperture for a step-index fibre. (5)
- (b) How fast would a rocket have to go relative to an observer for its length to be contracted to 99 per cent of its original length? (5)
- (c) Explain in detail top-down and bottom-up approaches to prepare nanomaterials. (5)

Q. 4

- i. Define and explain what is gradient?
- ii. If $\alpha(x, y, z) = 3x^2y + y^3z^2$, then Calculate the gradient of $\alpha(x, y, z)$ at (1, 2, -3) (5)
- (a) What is absent spectra? Derive the condition for absent spectra in grating. (5)
- (b) Distinguish between SEM and AFM. (5)



Q. 5

- (a) What is the longest wavelength that can be observed in the fourth order for a transmission grating having 5000 lines per cm? (5)
- (a) Obtain the expression for Ampere's circuital law in point form. (5)
- (b) Find the maximum resolving power of a grating 2 cm wide with 6000 lines/cm illuminated by a light of wavelength 5890 Å (5)

Q. 6

- (a) With the schematic diagram explain the principle construction and working of Transmission Electron Microscope. (7)
- (b) What are the different techniques to synthesize nanomaterials? Explain any two of them in detail. (8)

Insert at least 10 dimensions

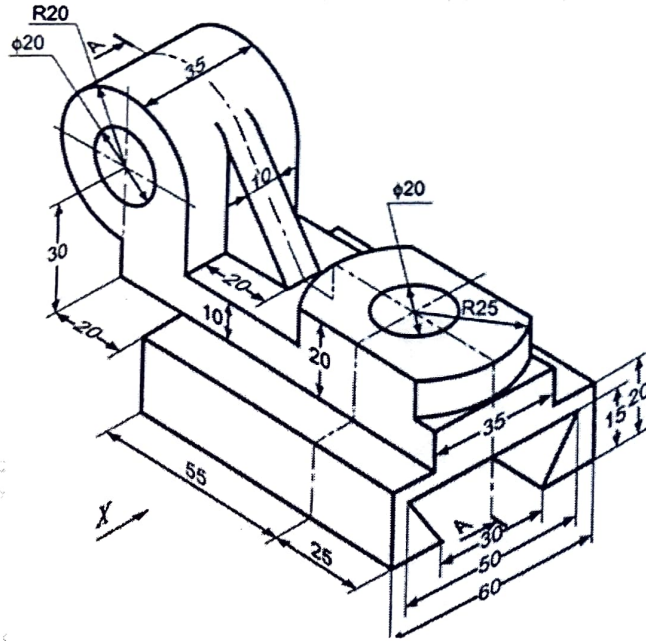

Figure 2

Q4

A right circular cone of diameter 60 mm and axis 75 mm is resting on HP. It is cut by section plane inclined to HP such that the true shape of the section is a parabola with axis equal to 50 mm. Draw Sectional TV, FV and the true shape of the section.

15

Q5. a)

Figure 3 shows the front view and top view of an object. Draw its isometric view.

9

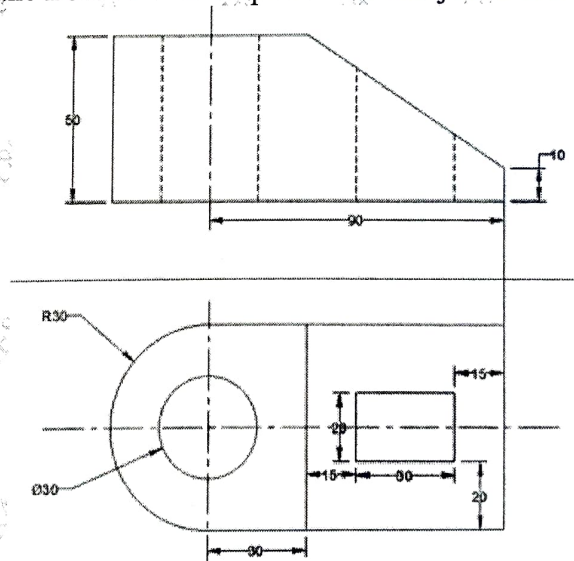

Figure 3

b)

A square prism side of base 40 mm and axis length 60 mm has its corner of base on VP and the base is inclined 45 degrees to VP. Draw projections of the prism.

6

- Q6 a) One end "A" of the line AB is 15mm above HP and 25mm in front of VP. The FV of the line measures 60mm and inclines 50 degrees to XY line. Draw projections of the line and find its inclination with HP and VP if the true length of the line is 75 mm. Consider the line being in first quadrant only. 9
- b) Draw the isometric view of the given views in figure 4. 6

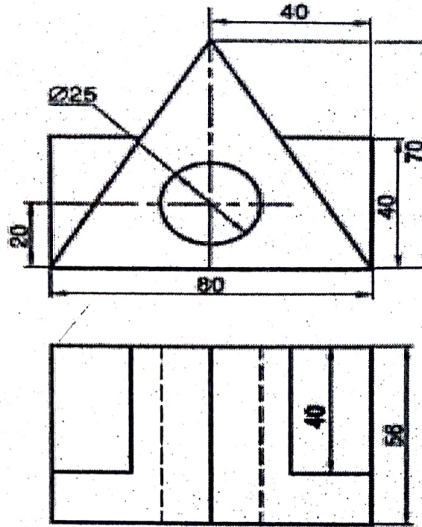

Figure 4



Ql code: 10064317

FE sem II R-19 scheme all branched

18/12/24

(Time : 2 hours)

(Total Marks: 40)

NB: Q1. is compulsory.

Attempt any Three out of the remaining Five questions.

Figures to the right indicate full marks.

Answers to the sub questions should be grouped together.

Q1. Answer the following questions:

- A. What is Communication? Explain any four methods of nonverbal communication. (10)
B. Write disadvantages of Grapevine Communication. (05)
C. Write a short note on types of feedback. (02)

Q2. Answer any 2 out of 3 questions:

- A. i. Importance of communication. (10)
ii. Correct the errors in the following sentences (03)
a. Did you pay your rent yet? (02)
b. It certainly must have been her.

B. Draw Diagrammatic Representation of Complete Block Style. (05)

C. What are the 7 Cs of business correspondence? Explain the ways in which these can be achieved in business letters. (05)

Q3. Solve Any Two :

- A. i. Write a technical description of a printer under the following headings: (10)
a) Definition b) Diagram c) Description of Components d) Working. (03)
ii. Give examples of the British and the American methods of writing the date. (02)
- B. i. Write a short note on paralanguage. (03)
ii. Provide one word substitute for the following sentences: (02)
a. That which can be seen through
b. One who offers one's services.
- C. Goods were assured to be delivered within two weeks of placing the order. But you (05)
have not yet received the goods, write a letter to your supplier, pointing out the delay and
specifying a date by which you wish to get the goods.

Q4. Do as directed:

A. Fill in the blanks: (10)

- i. lets the recipient know at a glance what it is about.
ii. Halo and effect is a kind of psychological barrier,
iii. Differences in position and authority can create a barrier.
iv. Chronemics is an aspect of non-verbal communication related to.....
v. The two methods of verbal communication are and

B. Match the following :

- (i) Resume (a) our reference
(ii) Full block form (b) logo/emblem
(iii) FB/104/ 07 (c) C.V.
(iv) Letterhead (d) salutation
(e) No indents

(02)



- C. Define: (i) Pendrive (ii) Calculator (iii) Voltmeter (03)
 D. State the difference between hearing and listening (02)

Q5. Answer any 2 out of 3 questions: (10)

- A. i. Write the description of Induction Plate with the definition, labeled diagram and working (03)
 ii. State whether the following statements are true or false (02)
 a. The meaning of the message is not in the words
 b. The salutation in a business letter changes according to the inside address.
- B. Write short note on: (i) Inside Address (ii) Downward communication (05)
 C. i. Distinguish between Caution and warning, (03)
 ii. What do the following gestures suggest (02)
 a. yawning b. Crossed arms c. Clenched fists d. Nail biting

Q6. Answer any 2 out of 3 questions: (10)

- Q6 A.** Read the following passage and answer the following questions. (05)

Radically changing monsoon patterns, reduction in the winter rice harvest and a quantum increase in respiratory diseases- all part of the environmental doomsday scenario which is reportedly playing out in South Asia. According to a United Nations Environment Programme report, a deadly three-km deep blanket of pollution comprising a fearsome cocktail of ash, acids, aerosols and other particles has enveloped this region. For India, already struggling to cope with a drought, the implications of this are devastating and further crop failure will amount to a life and death question for many Indians. The increase in premature deaths will have adverse social and economic consequences and a rise in morbidities will place an unbearable burden on our crumbling health system. And there is no one to blame but ourselves. Both official and corporate India has always been allergic to any mention of clean technology. Most mechanical two wheelers roll off the assembly line without proper pollution control systems. Little effort is made for R & D on simple technologies, which could make a vital difference to people's lives and the environment.

However, while there is no denying that South Asia must clean up its act, skeptics might question the timing of the haze report. The Johannesburg meet on Rio+10 is just two weeks away and the stage is set for the usual battle between the developing world and the West, particularly the U.S. President, Mr. Bush has adamantly refused to sign any protocol, which would mean a change in American consumption. U.N. environment report is likely to find a place in the U.S. arsenal as it points an accusing finger at countries like India and China. Yet the U.S. can hardly deny its own dubious role in the matter of erasing trading quotas. Richer countries can simply buy up excess credits from poorer countries and continue to pollute. Rather than try to get the better of developing countries, who undoubtedly have taken up environmental shortcuts in their bid to catch up with the West, the U.S. should take a look at the environment profligacy, which is going on within. From opening up virgin territories for oil exploration to relaxing the standards for drinking water, Mr. Bush's policies are not exactly beneficial- not even to Americans. We realize that we are in this together and that pollution anywhere should be a global concern. Otherwise, there will only be more tunnels at the end of the tunnel.

- i. Both official and corporate India is allergic to
 a. failure of monsoon

- b. poverty and inequality
 - c. slowdown in industrial pact
 - d. mention of monsoon technology
 - e. crop failure
- ii. Which, according to the passage, is a life and death question to many Indians?
- a. increase in respiratory diseases
 - b. use of clean technology
 - c. thick blanket of pollution over the region
 - d. failure in crops
 - e. dwindling agricultural yield
- iii. Choose the word which is similar in meaning to the word 'profligacy' as used in the passage.
- a. wastefulness
 - b. conservation
 - c. upliftment
 - d. criticalness
 - e. denouncement
- iv. What we must realize, according to the passage?
- a. no country should show superiority over other countries
 - b. U.N. is putting in hard efforts in the direction of pollution control
 - c. all countries must join hands in fighting pollution
 - d. nobody should travel through tunnel to avoid health hazards
 - e. we must strive hard to increase agricultural production
- v. Choose the word which is most opposite in meaning to the word 'morbidity' as used in the passage
- a. powerfulness
 - b. softness
 - c. healthiness
 - d. acuteness
 - e. purposefulness
- B.** Being the Sales Manager of Apha Technologies, Andheri (W), Mumbai, you have received an annoyed letter from one of your wholesale distributors about the manufacturing defect in the batteries of the laptops that they have bought from your company recently. Draft a suitable reply using the full block form. (05)
- C.** Write a complete set of effective instructions for welding two pieces of metal together. (05)



FE Sem II R-19 Cscheme All Branches

16/12/24

Time: 2 Hours

Max. Marks: 60

NB: 1) Question No.1 is compulsory.

2) Attempt any three questions from question no. 2 to 6.

- | | | |
|---------------|--|---------------|
| Q1 | Solve any three out of the following. | 15 |
| A | Define Algorithm. Write an Algorithm to find the largest of three accepted numbers. | 05 |
| B | Explain the importance of break and default in Multi-way branching statement. | 05 |
| C | Why there is a need to write function prototype in a program? What is the syntax for writing function prototype? | 05 |
| D | Explain the following functions with proper example. | 05 |
| | i) gets() ii) puts() | |
| E | Differentiate between Call by value and Call by reference . | 05 |
|
Q2 | |
15 |
| A | Explain the organization of Standard Library of C language with Example. | 05 |
| B | Write a program to find the reverse of a given number. | 05 |
| C | Write a program to find GCD of two natural numbers using Euclid's Algorithm which is defined as below. | 05 |
| | GCD(m, n)=GCD(n, m) if n>m | |
| | = m if n=0 | |
| | = GCD(n, m%n) Otherwise | |
|
Q3 | |
15 |
| A | Explain the Right and Left Shift Bitwise operators with proper example. | 05 |
| B | Differentiate between for loop and do-while loop . | 05 |
| C | Explain the concept of actual parameters and formal parameters. | 05 |
|
Q4 | |
15 |
| A | Write a program to accept and sort 'n' elements of one dimensional array in ascending order. | 05 |
| B | Explain the Reference and Dereference operator with proper example. | 05 |
| C | Differentiate between Structure and Union . | 05 |
|
Q5 | |
15 |
| A | Write a program to calculate and display all the roots of a quadratic equation. The quadratic equation can be expressed in the form $ax^2 + bx + c = 0$, where 'a' is not equal to zero. The program should prompt the user to input the values of a, b, and c, and then calculate. | 10 |
| B | Write a program to accept a string and display its length without using standard string library function. | 05 |



Q6

15

A A Hospital needs to maintain details of patients. Details to be maintained are First name, Middle name, Surname, Date of Birth, Disease.
Write a program which will print the list of all patients with given disease. Use the concept of Nested Structure for Date of Birth.

10

B Write a program using concept of pointer to an array to display the content of an array in reverse order. Use pointer Arithmetic.

05