

Time: 3 hours

Marks: 80

N.B. (1) Question No. 1 is compulsory.

(2) Answer any three questions from Q.2 to Q.6.

(3) Use of Statistical Tables permitted.

(4) Figures to the right indicate full marks

Q1 A If  $f(t) = (\sqrt{t} + \frac{1}{\sqrt{t}})^2$ , find  $L[f(t)]$  and hence find  $L\{e^{2t}f(t)\}$  5

B Find  $L^{-1}\left\{\frac{1}{s(s^2+4)}\right\}$  5

C Obtain half-range cosine series for  $f(x) = x(2-x)$  in  $0 < x < 2$  5

D Find moment generating function of the following distribution. Hence find mean and variance. 5

X	1	3	4	5
P(X)	0.4	0.1	0.2	0.3

Q2 A Find the orthogonal trajectories of the family of curves  $e^{-x}[x \sin y - y \cos x] = c$  6

B Find  $L\left\{t\left(\frac{\cos t}{e^t}\right)^2\right\}$  6

C Find the Fourier series expansion for  $f(x) = 2, -2 < x < 0.$   
 $= 0, 0 < x < 2$  8

Hence deduce that  $\frac{\pi^2}{8} = \frac{1}{1^2} + \frac{1}{3^2} + \frac{1}{5^2} + \dots$

Q3 A Find  $L^{-1}\left\{\log\left(1 - \frac{1}{s^2}\right)\right\}$  6

B Find the analytic function  $f(z) = u + iv$  where  $u + v = \frac{\sin 2x}{\cosh 2y - \cos 2x}$ , using Milne-Thompson's Method. 6

C Fit a parabola  $x = a + by + cy^2$  for the following data: 8

X :	1	2	3	4	5
Y :	10	12	15	14	15

- Q4 A The first 4 moments of a distribution about origin of the random variable X are -1.5, 17, -30 and 108. Compute Mean, variance,  $\mu_3$  and  $\mu_4$ . 6
- B Consider the equations of regression lines  $5x-y=22$  and  $64x-45y=24$ . Find  $\bar{x}$ ,  $\bar{y}$  and correlation coefficient r. 6

C Find  $L^{-1}\left\{\frac{(s+3)^2}{(s^2+6s+13)^2}\right\}$  8

- Q5 A Find the Laplace transform of  $\cos^3 t \cos 5t$ . 6
- B Find Spearman's rank correlation coefficient for the data below: 6

X :	32	55	49	60	43	37	43	49	10	20
Y :	40	30	70	20	30	50	72	60	45	25

- C Obtain Fourier Series for  $f(x) = \frac{1}{2}(\pi - x)$  in  $(0, 2\pi)$ . 8
- Hence, deduce that  $\frac{\pi}{4} = 1 - \frac{1}{3} + \frac{1}{5} - \frac{1}{7} + \dots$

- Q6 A If  $f(x)$  is probability density function of a continuous random variable X, find k, mean and variance. 6

$$f(x) = \begin{cases} kx^2, & 0 \leq x \leq 1 \\ (2-x)^2, & 1 \leq x \leq 2 \end{cases}$$

- B Check if there exists an analytic function whose real part is  $u = \sin x + 3x^2 - y^2 + 5y + 4$ . Justify your answer. 6

- C Evaluate the following integral by using Laplace transforms 8

$$\int_0^{\infty} e^{-2t} \left[ \int_0^t \left( \frac{e^{3u} \sin^2 2u}{u} \right) du \right] dt$$

Duration: 3 Hours

Total Marks: 80

- N.B. :** 1) Question Number 1 is compulsory  
 2) Solve any three questions from the remaining questions  
 3) Make suitable assumptions if needed  
 4) Assume appropriate data whenever required. State all assumptions clearly.

**Q.1**

**Solve any four of the following questions.**

- a.** What is a tautology? Check whether the following logical expression is tautology? 5  
 $[(p \rightarrow r) \wedge (\sim q \rightarrow p) \wedge \sim r] \rightarrow q$
- b.** State the Pigeonhole principle and show that if any five numbers from 1 to 8 are chosen, then two of them will add to 9. 5
- c.** Convert the following into CNF form. 5  
 $(A \rightarrow B) \rightarrow ((B \rightarrow C) \rightarrow (A \rightarrow C))$
- d.** Given  $S = \{1, 2, \dots, 10\}$  and a relation  $R$  on  $S$ , where  $R = \{(x, y) \mid x + y = 10\}$ . Is it reflexive, symmetric, transitive, antisymmetric? 5
- e.** Define the following terms 5  
 1. Planer graph 2. Cut Vertex 3.Chain 4. Monoid 5.Group

**Q.2**

- a.** Let  $A = \{p, q, r, s\}$  and let  $R = \{(p, p), (p, q), (p, r), (q, p), (q, q), (r, p), (q, r), (r, q), (r, r), (s, s)\}$ . Show that  $R$  is an equivalence relation. Determine the equivalence classes and find the rank of  $R$ . 8
- b.** Show that  $A = \{0, 3, 6, 9, 12\}$  is a ring w.r.t. the operation of addition & multiplication modulo 15. 8
- c.** Explain two different types of Quantifiers with example? 4  
 Represent the following sentences using First Order logic  
 i) Some students took GenAI.  
 ii) Every student who takes GenAI passes it.

**Q.3**

- a.** What is an Abelian Group? Let  $G = \{1, 2, 3, 4, 5, 6, 7\}$  8  
 i) Prepare the composition table w.r.t the operation of multiplication modulo 8.  
 ii) Check whether it is an Abelian group? Justify your answer.
- b.** Define minimum hamming distance. Find the code words generated by the parity check matrix  $H$  given below. 8

$$H = \begin{pmatrix} 1 & 0 & 1 \\ 0 & 1 & 1 \\ 1 & 1 & 0 \\ 1 & 0 & 0 \\ 0 & 1 & 0 \\ 0 & 0 & 1 \end{pmatrix}$$

c

4

Determine whether the following graph is Eulerian or Hamiltonian or both. Justify your answer.

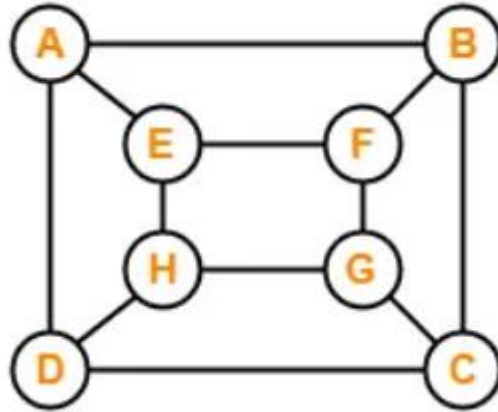

Q.4 a

Define function. What are three different types of functions.. Consider the function  $f$  and  $g$  from  $N \times N$  to  $N$  given by  $f(x,y) = 2x+y$  and  $g(x,y) = xy$ , identify its type.

8

b

Let  $A = \{a,b,c,d,e\}$  and let  $R$  be a relation on  $A$ .

8

Let  $R = \{(a,a), (a,c), (b,b), (c,d), (c,e), (d,a), (e,b), (e,e)\}$

Compute transitive closure using Warshall's algorithm

c

Prove using Mathematical Induction that sum of cubes of three consecutive integers is divisible by 9.

4

Q.5 a

Let  $X = \{1,2,3,4,6,24,36,72\}$  and  $R = \{(x,y) \in R \mid x \text{ divides } y\}$

8

i) Write the pairs in a relation set  $R$ .

ii) Construct Hasse diagram.

iii) Mention Chains and Anti Chains from above set.

iv) Is it a lattice?

b

Find the number of integers between 1 to 500 that are not divisible by 5,6, or 8?

8

c

Check whether the following graphs are Isomorphic or not? Justify

4

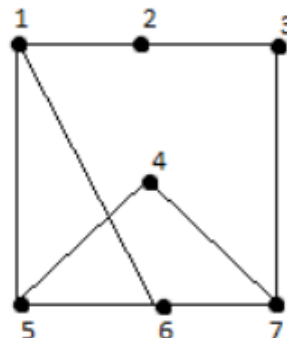
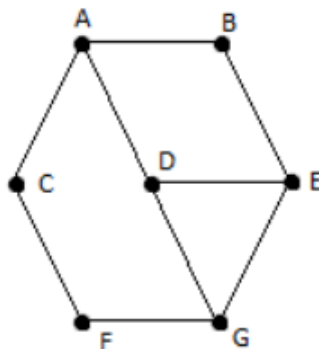

- Q.6.**
- a** Draw the Hasse Diagram of  $D_{72}$  **8**
    - i) Find the complement of each element
    - ii) Check whether it is a Distributive Lattice
  - b** Let  $f(x) = x + 3$ ,  $g(x) = x - 3$  and  $h(x) = 3x$  for  $x \in \mathbb{R}$ , where  $\mathbb{R}$  is the set of real numbers. **8**
    - Find i)  $g \circ h$  ii)  $f \circ g$  iii)  $g \circ h \circ f$  iv)  $f \circ h \circ g$
  - c** Find the generating functions for the following sequences: **4**
    - a.  $0, 0, 0, 1, 2, 3, 4, 5, 6, 7, \dots$
    - b.  $6, -6, 6, -6, 6, -6, \dots$
-

(3 Hours)

Total Marks: 80

- N.B:** (1) Question No. 1 is compulsory.  
 (2) Attempt any three questions out of the remaining five questions.  
 (3) Figures to the right indicate full marks.  
 (4) Make suitable assumptions wherever necessary.

- Q.1 (a) Differentiate between linear and non-linear data structures. [05]  
 (b) Evaluate postfix expression “78+45-\*” using stack. Show stack contents at each step. [05]  
 (c) Explain the various ways to represent graph in the memory with example. [05]  
 (d) Write a C function to insert and delete an item in linear queue as linked list. [05]
- Q.2 (a) Construct Huffman tree for the letters in the string “structures” and find the Huffman codes for each symbol in the string. [10]  
 (b) Write C program for infix to postfix conversion. [10]
- Q.3 (a) Write a C program to perform following operations on a doubly linked list:  
 i) insert a node from the end of the list, ii) delete first node,  
 iii) display the list. [10]  
 (b) Write a C functions to insert and delete elements with respect to binary search tree. [10]
- Q.4 (a) Construct an AVL tree by inserting the following elements in the given order:  
 74, 23, 120, 65, 11, 31, 42, 55, 98, 7. [10]  
 (b) Explain the double ended queue. Explain its types. [05]  
 (c) Define topological sorting. Explain the same with suitable example. [05]
- Q.5 (a) Given the values {91, 82, 43, 37, 69, 24, 61}, a hash table of size 7 and a hash function  $h(k) = k \text{ mod } 7$ , show the resulting table after inserting the values in the given order with Linear probing. [10]  
 (b) Write an algorithm to check the well-formedness of parenthesis in an algebraic expression using the Stack data structure. [10]
- Q.6 (a) Insert the given elements in the following B-tree of order-3:  
 75, 59, 86, 64, 53, 40, 29, 4. [10]

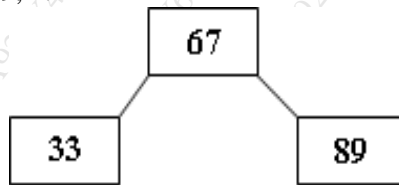

- Show the B tree at each step of insertion.  
 (b) Write a function in C for BFS traversal of graph. Explain DFS graph traversal with suitable example. [10]

\*\*\*\*\*

(Time: 3 hours)

(Total Marks: 80)

- N.B. 1. Question No. 1 is compulsory  
 2. Attempt any **three** questions from remaining five questions  
 3. Assume suitable data if **necessary** and justify the assumptions  
 4. Figures to the **right** indicate full marks

Q1	a	Draw the Detailed Von- Neumann architecture and explain in brief	05
	b	Explain IEEE-754 Floating point Representation	05
	c	Explain the difference between Encoder and decoder	05
	d	Differentiate between Hardwired control unit and Micro programmed control unit	05
Q2	a	List out the basic and universal logic gates with the symbol, truth table, output expression	05
	b	What do you mean by BCD? Perform $792 + 128$ using BCD addition	05
	c	Explain the various Addressing Modes	10
Q3	a	What is the difference between Computer organization and Computer architecture explain it with a example	05
	b	List & explain the characteristics of memory	05
	c	Draw the Flowchart for the Booth's Algorithm for signed integer multiplication and perform the multiplication between $-6$ and $2$ using this Algorithm	10
Q4	a	List the various methods to design the Hardwired control unit and explain any one	05
	b	Explain the Micro instruction format	05
	c	Explain Flynn's Classification	10
Q5	a	List and explain the various pipeline Hazards	05
	b	Write a microprogram to represent the Interrupt cycle	05
	c	Consider a 2-way set associative mapped cache of size 16 KB with block size 256 bytes. The size of main memory is 128 KB. Find- 1. Number of bits in tag 2. Tag directory size	10
Q6	a	Represent $-7.14$ using double precision format of IEEE 754 standards	05
	b	Explain the concept of locality of reference	05
	C	Explain the various Bus arbitration methods	10

Duration: 3 Hours

Total Marks 80

**N.B:** 1) Question **number 1** is compulsory.

2) Attempt **any three** out of the remaining.

3) Assume suitable data if **necessary** and justify the assumptions.

4) Figures to the **right** indicate full marks.

**Q.1** Attempt **any four**

**20**

- i. Give applications of Computer Graphics.
- ii. What is an antialiasing? Explain any 3 antialiasing techniques.
- iii. Compare DDA and BRESENHAM line drawing algorithm.
- iv. Explain Viewing transformation pipeline.
- v. Give fractal dimension of Koch curve.

**Q.2**

**20**

- a. Given a line AB where A(0,0) and B(1,3) find out all the coordinates of line AB using DDA algorithm.
- b. Describe different traditional animation techniques.

**Q.3**

**20**

- a. Describe homogeneous coordinates.
- b. Describe with neat diagram Boundary Fill and Flood fill algorithm.

**Q.4**

**20**

- a. Derive window to viewport coordinate transformation.
- b. Derive matrix for 2D rotation at any arbitrary (fix) point.

**Q.5**

**20**

- a. Give properties of Bezier curve.
- b. Describe with neat diagram Sutherland Hodgman polygon clipping algorithm.

**Q.6**

**20**

- a. Describe with neat diagram Depth Buffer algorithm.
- b. What is projection? Explain with neat diagram different perspective projections.